

On the essentials of Combined Heat and Power (CHP) and the great benefits it brings to energy- and climate policy in the Netherlands

The essentials of Combined Heat and Power (CHP, or cogeneration) can only be appreciated when taking an integral look at energy supply systems. This paper uses such an approach and will illustrate the benefits thereof by looking to the CHP situation in the Netherlands.

1. Electricity is a minor energy use. Heat is 3 times as important

Energy comes in many forms. Fuels, like coal, gas, uranium; electricity; light; heat or motion are all forms of energy. They can be converted from one from to another. Thereby no energy is lost, but on conversion not all input energy is put into the desired form. At conversion of fuels to electricity for example quite some energy input turns to (often useless) heat output. While most of the public and political debate regarding energy concentrates on (sustainable) electricity like wind or solar energy, electricity is far from the most important form of energy. In the Netherlands energy for heating is more then 3 times as important. Also the energy use for mobility exceeds the energy used for electricity, as is illustrated in the ECN data below.

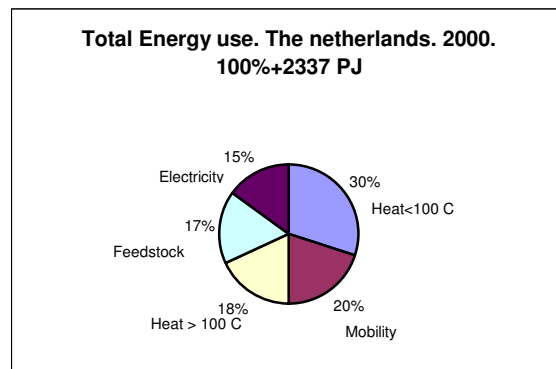

2. Combining Heat and Power doubles efficiencies

Roughly speaking the efficiency with which fuels like gas or coal can be converted into useful other forms like electricity or heat can be doubled when combining the production of heat and power, compared with the separate production thereof. In the Netherlands the actual energy efficiency of the total electricity production is around 42%. Modern CHP plants achieve overall efficiencies ranging from 85-95%. Great physical savings of fuel and emissions result that, if properly priced, can yield good financial rewards to the CHP plant operator. Note that a gas fired CHP plant emits only 200 gr. CO₂/kWh versus more than 1000 gr. CO₂/kWh for a non-CHP coal or lignite fired electricity power plant

WKK superieure energie efficiëntie

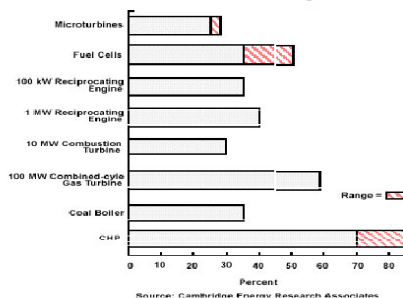

Source: Abtom at WEC congress 2001

CHP has superior carbon efficiency versus other power technologies

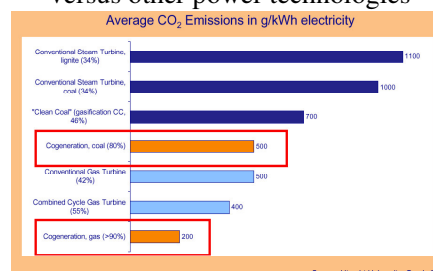

Source: Cogen Europe at Cogen Europe conference 2003

3. CHP is big in the Netherlands

Thanks to favourable and consistent stimulation CHP grew during the period 1985-1995 to become the largest conversion technology in use in the Netherlands. Abundant supply of natural gas and the existence of modern energy-intensive industry, requiring lots of heat were other favourable conditions for this success. Liberalisation of energy and still (very) imperfect fuel-, electricity- and environmental markets have brought the growth to an end, although lots of good potential is still available.

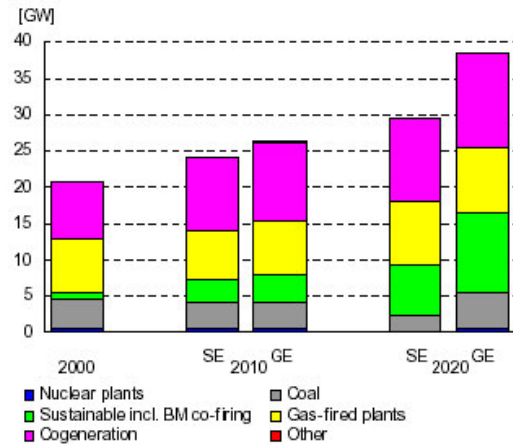
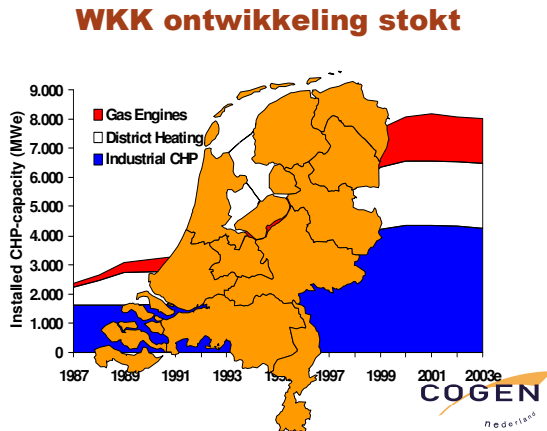

Figure 7.1.4 - Development of production capacity, 2000-2020, SE and GE

4. CHP plants are broadly spread, adding to stability

In the Netherlands 50% the 7500 MWe installed 2004 CHP capacity stands in the industry, of which about half in the chemical industry. District heating takes a quarter. Typically Dutch is the 12% of CHP capacity used in agricultural greenhouses. Around 100 combined cycle CHP's dominated in installed capacity, while around 3400 smaller gas engine CHP dominate in number of installations, according to ECN/MNP in the may 2005 reference estimate study.

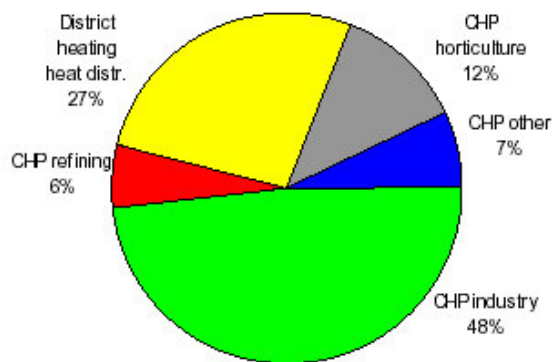

Figure 7.2.1 - Composition of cogeneration capacity according to sector [% installed capacity]

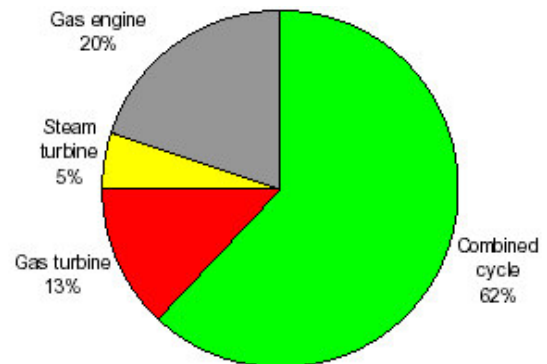
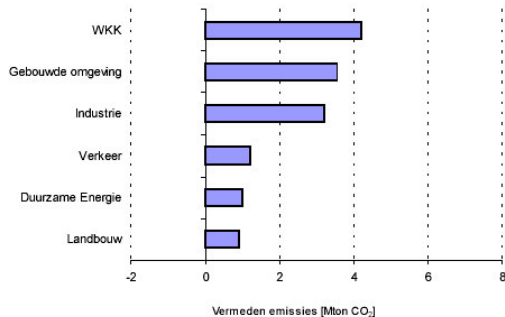

Figure 7.2.2 - Composition of cogeneration capacity, according to type of technology [% installed capacity]

5. CHP brought/brings great benefits to Dutch energy and climate policy.

CHP (WKK in Dutch) brought the largest CO₂ emission reductions of all policy instruments applied in the 1990-2000 period. More over CHP support turns out to be the most cost-efficient of all policy instruments, as shown in ECN studies. CHP saves about 100 PJ of energy on a total of 2400 PJ national consumption. CHP is the largest and most effective energy saving policy applied or foreseen in Dutch policy. Unfortunately all these benefits are declining since 2000, due to liberalisation, imperfections in markets and reduced or disappearing Dutch governmental policy on CHP.



Figuur 10.1 Effect van beleid op de emissie van CO₂ in Nederland in de periode 1990-2000.

Tabel 4.3 Subsidie-effectiviteit van enkele subsidieregelingen voor de overheid¹

Optie	Regeling	[€/ton CO ₂]
Warmtekrachtkoppeling	MEP	25
Diermeel (verbranden)	MEP	50
Stortgasbenutting	MEP	50
Meestook biomassa in kolencentrales	MEP	75
Dubbel glas	EPR-oud	160
Hoog Rendementsketel	EPR-oud	
Woningisolatie	EPR-oud	
Extra energiezuinig witgoed	EPR-oud	200
Wind op land	MEP	
Zuivere biomassa	MEP	200
Zonneboilers	EPR-oud	250
Bio-installatie	MEP	250
Wind op zee	MEP	250
Golf- en getijdenenergie	MEP	250
Zonnecellen (PV)	MEP	250
Zonnecellen (PV)	EPR	990
Hybride auto (elektrisch/benzine)	Fiscaal verkeer	1400

6. Transport economics make heat local business. Electricity is regional business

The economics of transporting energy are heavily dependent on the form of energy. A given amount of energy in the form of coal, crude oils or gas can travel by ship or pipeline for thousands of miles. Once converted into electricity transport requires expensive overhead power lines and distribution cables. During transport of electricity losses occur, causing costs. These costs of transport and distribution of electricity often add up to half of the delivered costs at the point of use. Therefore the same amount of energy in the form of electricity can be transported economically less far, roughly only over a tenth of the distance fuels can travel. For distances over 300-500 kilometres it is more economical to build a new power plant and transport the fuels. The transport of heat is again more difficult and costly. Heat travels only a couple of miles, a factor 10 less again than electricity. For longer distances it pays to erect a new fireplace or boiler and to transport the fuels instead of the heat itself. Motion is purely local and can mechanically be transported only over a few hundred meters. These economics make fuels a world commodity, electricity is a regional or national business, while heat is a local business. Minimalization of energy transport costs drives decentral energy.

7. Combining Heat and Power is therefore a local, decentral business

Because of the small distances over which heat can be transported economically, combining heat and power can only be done in the proximity of an useful application of heat. This can be either an industrial, chemical or refinery process or an application for spatial heating like in agricultural greenhouses, offices or domestic houses via district heating. In all cases the CHP plant has to be at a reasonable close distance to the heat user. From the perspective of the electricity sector – quite often consisting of big, central plants at remote locations where cooling water is available – CHP is therefore seen as being a decentral form of electricity generation. Actually CHP is the strongest contributor to the success of decentral energy, as its efficiency is better than central alternatives. In other fields of energy conversion – coal fired electricity, nuclear power, wind farms – central conversion generally has higher efficiencies than smaller decentral applications, leading to big power plant or wind farms. Decentral CHP is more efficient because its decentral nature allows it to double the efficiency by putting the heat – otherwise cooled away in river or air - to a useful application. It also avoids great instalment and operational costs for the transport and distribution networks.

8. The Netherlands have a relatively very decentral electricity system.

Small, rich, well electrified the Netherlands has the world's highest energy use per square kilometre. A prosperous population, the climate and a relatively large energy-intensive industry are reasons for this. The Dutch power generation grew bottom-up out of city and provincial energy companies, leading to a nice spread of sites for central power plant. Well spread CHP plants add to the stability and savings as well. An efficient ring-form grid, on which electricity is feed in on various voltage levels, gives stability, failure reduction and savings. Pictures below by TenneT, show the Dutch electricity grid and the different voltage levels on which power is fed in and taken of the grid. Note the relative large feed-in on lower voltage levels.



Verdeling van afname en invoeding over netvlakken

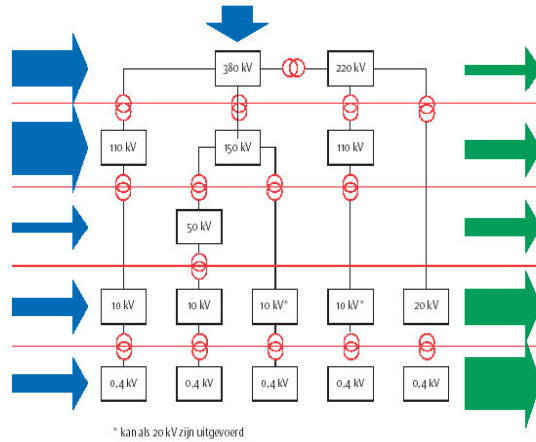

9. Combined Heat and Power production has enormous benefits

The integral approach to energy, leading to combined fuel conversion to both heat and power at the same time and location, realises great benefits. CHP overcomes the fundamental problem of electricity generation i.e. the lack of efficiency of its conversion. In the OECD more than 60% of the energy input to electricity production turns into useless heat, cooled away in rivers or into the air according to the OECD statistics pictured below. This is because of laws of nature an inevitable process. At conversion of fuels 60% of the input energy turns into heat and only 40% into electricity. The only difference between a CHP plant and a "normal" power plant is that a CHP plant puts the heat to an useful application, while in a regular power plant it is only used to useless heating up the cooling water and environment.

Electricity Generation in European OECD countries (in TWh)

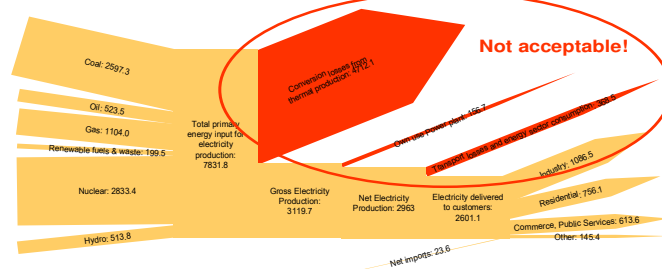

33% total efficiency of the electricity supply system

Source: OECD 1999

10. On realising CHP potential: awareness, context, policy and instruments

The realisation of CHP benefits takes place in the physical world of m³, tons, kWh and Joules. Societies have given governments a range of instruments to realise desired results in the physical world. Laws and regulations give commands and prohibitions. Taxes and subsidies realize financial penalties or incentive. Impacting the structure of the energy industry by liberalisation, regulation, internalisation of not yet incorporated external factors are other instruments for energy policy. These days many believe “The Invisible Hand” to do the job.

The Dutch CHP growth in the 1985-1995 period resulted from a good awareness of CHP potential in a context of a governments owned and controlled energy sector. The policy to promote CHP used consistently favourable investment tax breaks, reduced natural gas prices and an attractive feed-in tariff.

The change of context towards liberalisation created financial losses for CHP plants as Dutch high (heavily taxed) gas prices and low electricity prices (mainly set by heavily subsidised German coal-fired import electricity) leave insufficient spark spread to cover extra investment costs and the reduced flexibility of CHP compared to separate production. Lack of financial reward for the environmental benefits is the most fundamental reason for depressed financials. As CHP plants cannot recover their full costs under the liberalised market conditions the Dutch government has put a support scheme in place that compensates the losses for 30-50% and thereby stops further erosion.

Increasingly awareness of the urgent energy- and environmental problems to resolve helps to bring CHP again in the picture of policy makers. Dutch government will publish a new policy to promote growth of CHP in spring 2006. Next to that it recognizes that “business as usual”, leading to gradual, technological innovation and improvement, will not resolve the challenges enough and in time. The Dutch government therefore follows a transition policy aiming to complement technological innovation with system innovation.

Transition policy

Solving the major environmental problems requires system innovation; in many cases this can take on the form of a long drawn-out transformation process comprising technological, economic, socio-cultural and institutional changes. The period until such a transformation is complete can be seen as a transition. During the transition, objectives are formulated and modified and interrelated policy instruments are applied. Transitions require a type of co-ordination by the government with the concepts of uncertainty, complexity and cohesion at its core. Long-term thinking is the frame of reference in which short-term decisions must be taken. Transition management requires that the government learns to deal with uncertainty, in part by working with scenarios, paying attention to the international dimension of processes of change and keeping options open as long as possible. In the following chapters, the principles of transition management are applied to the major problems identified in chapter 2 of this policy document.

11. CHP is innovative

At different levels (applying) the CHP principle is highly innovative.

At the high level of the (national) energy system CHP forms the ultimate system innovation. It combines two major field of energy use: heat and electricity. Co-generating heat and electricity and putting both to an useful application is the ultimate energy system integration. It generates the fabulous benefits discussed above. It recognizes that while converting fuels

into electricity unfortunately efficiencies are limited to the maximum of 60% for gas and only 45% for coal (and in practice much lower) while the remaining energies turn into heat.

Using that heat is the trick. Realistic assessment recognizes that it is better to speak from generating electricity as a side product while producing heat than the conventional reverse. CHP is the best of “out of the box” thinking. Out of the box of conventional electricity generation. Out of the box of heating and steaming. Combining these boxes, exploiting the fields of synergy, harvesting the benefits of a holistic approach: savings, sustainability, time for innovations...like adding cooling to the systems to from tri-generation plants!

In its truly synergetic nature applying CHP is different from “in the box” energy conversions like wind or solar power or co-firing biomass in electricity generation.

Moreover CHP benefits from all innovation and improvement in the realizing technologies, like improving efficiencies in gas turbines or emission reduction in gas motors.

12. Urgent need to apply the CHP principle

Next to all good pro-CHP arguments in the fight to counter climate change and to save fossil fuels, one other argument underlines the urgent need to apply the CHP principle: the coming shortage of cooling capacity! In the Netherlands this phenomena did almost trip the entire electrical system in summer 2003. Recently published Dutch governmental (MNP) reports do openly illustrate a rise of probability of cooling problems due to lower water availability at higher temperatures. Construction of big central power plants therefore increasingly concentrates on coastal locations with colder seawater, leading again to additional energy losses and network costs!

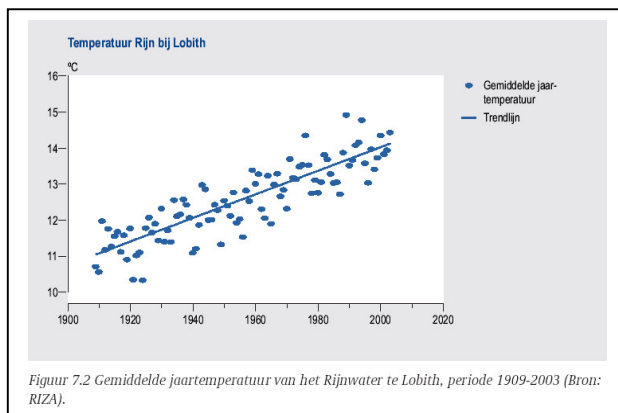
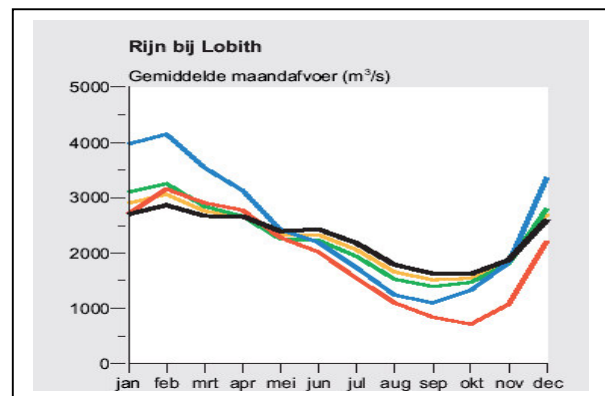
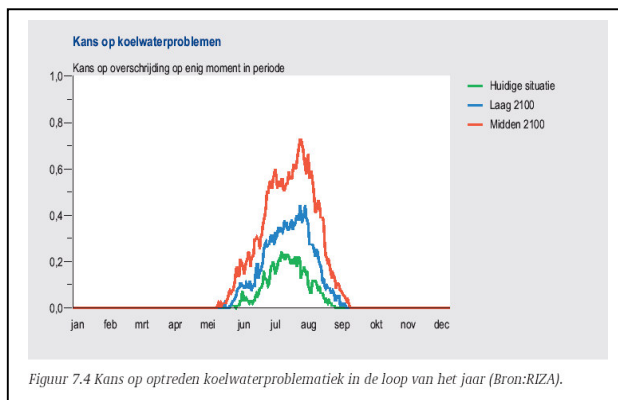

13. Imperfect liberalization hurts CHP economics

In today's imperfect markets, CHP is not the cheapest way to make electricity. In general it takes a little bit more capital to build a CHP plant, which often is a bit less flexible than a comparable power plant. Neither is CHP the easiest way to generate heat, like steam or warm water. Single boilers do a good and cost effective job. But CHP – combining heat and power conversion out of fossil fuels, and applying both usefully – gives great benefits to energy savings and emission reductions. And CHP – thanks to its decentral, reliable and predictable nature – contributes to reduction of costs of network capital and losses. The trouble for CHP is to reap the financial rewards for its desired qualities. CHP owners – in the Netherlands – favour liberalisation over governmental control, under the condition of good working markets and a level playing field. Good markets should include current externalities like emissions, dust production, visual burden, long-term waste issues and the impact on electricity networks into the economics of energy conversion. That currently not being the case CHP – and potentially other conversion methods – should be compensated for the shortfall that imperfect markets cause. Electricity's costs are heavily determined by the costs of fuel. As long as EU Members states in North West Europe heavily subsidize (Germany on coal) or tax (the Netherlands on gas) their local fuels, the creation of a level playing field on the electricity markets is an illusion. It is widely agreed that on good/perfect markets CHP will turn out to be the preferred conversion method for fossil fuels thanks to its intrinsic high efficiency. But until that time governments have to play an active role in promoting and supporting CHP.

14. CHP has a lot of potential, in the Netherlands and elsewhere in the EU

Notwithstanding the strong position of CHP in the Netherlands – 40-50% of the Dutch electricity comes from CHP – there is a lot of potential left. Partly in industry, also in greenhouses and in the built environment. Mini and micro CHP plants – down to 1kW capacity – are expected to play an increasingly big and smart role from 2010 onwards. Given its high density, good gas infrastructure, high prosperity and knowledge the Netherlands – that also have a vested interest to contribute to stopping the sea to rise due to climate change – are a ideal testing and development ground to further decentralised energy, with CHP at its core. Pictured below are the energy savings that can be realised in the Netherlands in the 2005-2020 period, with CHP (WKK) being among the top 3 policies, according to Ecofys. Applying CHP is the biggest EU solution to the Kyoto challenge, according the EU Cie.

